

FITTING INSTRUCTION

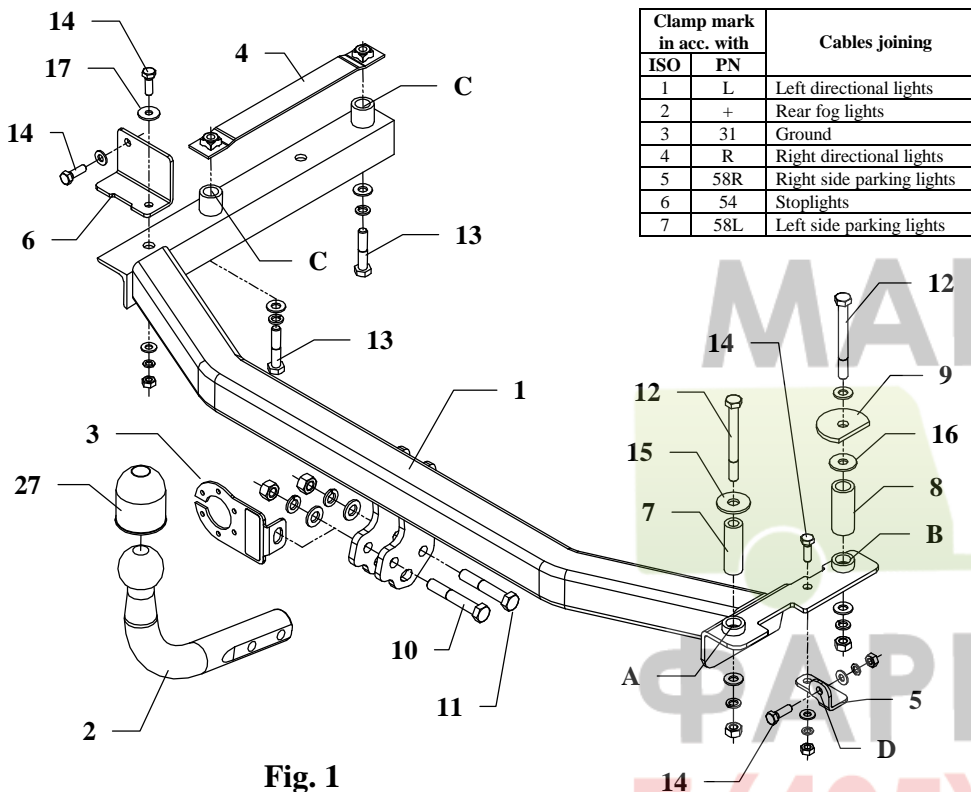

Fig. 1

This towing hitch is designed to assembly in following cars: **HONDA JAZZ 5 doors**, produced since 10.2008, catalogue no. **Y35** and is prepared to tow trailers max total weight **1000 kg** and max vertical mass **95 kg**.

Torque settings for nuts and bolts (8,8):

M6 - 11 Nm **M 8** - 25 Nm **M 10** - 50 Nm
M 12 - 87 Nm **M 14** - 138 Nm **M16** - 210 Nm

The instruction of the assembly

1. Disassemble bumper, on the left side disassemble support and mud guard. Under support cut out hole to open enter into chassis member.
2. Reassemble mud guard after cut out fragment according to figure 3.
3. Release exhaust pipe from two last holders.
4. Inside boot loosen right side panel.

5. According to figure 2 enlarge hole A (ca. $\varnothing 20\text{mm}$). Slip distance sleeve (pos. 7), put bolt M10x100mm (pos. 12) together with washer as shown in the figure 1.
6. On the left side put fish-plate with nuts (pos. 4) into chassis member.
7. Inside boot on the right side find factory made hole and slip into distance sleeve (pos. 8). Put bolt M10x100mm (pos. 12) and cut washer (pos. 9) as shown in the figure 1.
8. Fix right bracket (pos. 5) with main bar of the towbar (pos. 1) as shown in the figure 1. Apply main bar of the towbar to chassis and fix at points A, B, C and D as shown in the figure.
9. On the left side fix bracket (pos. 6) as shown in the drawing 1.
10. Reassemble bumper after cut out its fragment in central part, in bottom edge (width 50mm and depth 55mm).
11. Fix tow-ball (pos. 2) with socket plate (pos. 3) using bolts M12x75mm (pos. 10) and M12x70mm (pos. 11) from accessories.
12. Tighten all bolts according to the torque shown in the table.
13. Connect electric wires of 7-poles socket according to the instruction of the car. (Recommend to make at authorized service station).
14. Complete paint layer damaged during installation.

Towing hitch accessories:

Pos. 1 Main bar PCS.: 1	Pos. 7 Distance sleeve I $\varnothing 20 \times \varnothing 12 \text{mm}$ L=62mm PCS.: 1	Pos. 14 Bolt 8,8 B M8x25mm PCS.: 4	Pos. 21 Spring washer $\varnothing 12,2 \text{mm}$ PCS.: 2
	Pos. 8 Distance sleeve II $\varnothing 25 \times \varnothing 17 \text{mm}$ L=57mm PCS.: 1	Pos. 15 Plain washer $\varnothing 37 \times \varnothing 13 \times 3 \text{mm}$ PCS.: 1	Pos. 22 Spring washer $\varnothing 10,2 \text{mm}$ PCS.: 4
Pos. 2 Tow ball pcs.: 1	Pos. 9 Cut washer pcs.: 1	Pos. 16 Plain washer $\varnothing 30 \times \varnothing 10,5 \times 2,5 \text{mm}$ PCS.: 1	Pos. 23 Spring washer $\varnothing 8,2 \text{mm}$ PCS.: 3
Pos. 3 Socket plate PCS.: 1	Pos. 10 Bolt 8,8 B M12x75mm PCS.: 1	Pos. 17 Plain washer $\varnothing 24 \times \varnothing 8,4 \times 2 \text{mm}$ PCS.: 1	Pos. 24 Nut 8 B M12 PCS.: 2
Pos. 4 Fish-plate with nuts PCS.: 1	Pos. 11 Bolt 8,8 B M12x70mm PCS.: 1	Pos. 18 Plain washer $\varnothing 13 \text{mm}$ PCS.: 2	Pos. 25 Nut 8 B M10 PCS.: 2
Pos. 5 Right handle PCS.: 1	Pos. 12 Bolt 8,8 B M10x100mm PCS.: 2	Pos. 19 Plain washer $\varnothing 10,5 \text{mm}$ PCS.: 5	Pos. 26 Nut 8 B M8 PCS.: 3
Pos. 6 Left handle PCS.: 1	Pos. 13 Bolt 8,8 B M10x50mm PCS.: 2	Pos. 20 Plain washer $\varnothing 8,5 \text{mm}$ PCS.: 4	Pos. 27 Ball cover PCS.: 1

Fig. 2. Enlargement of hole A.

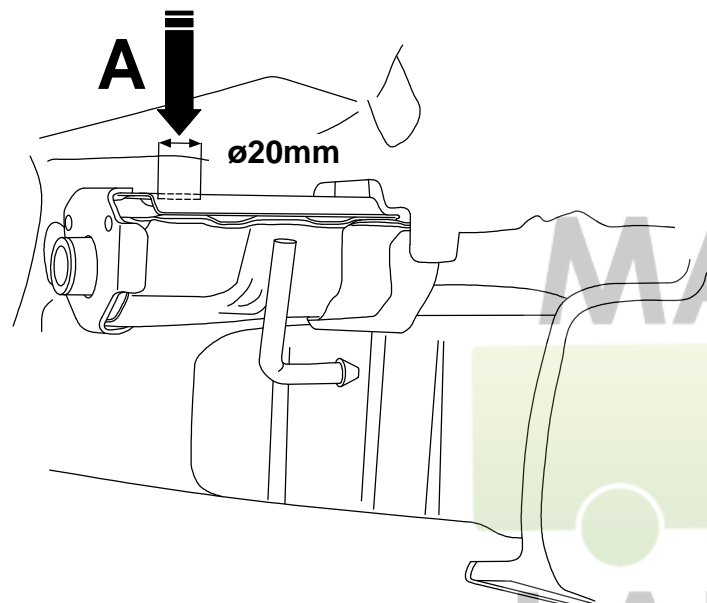
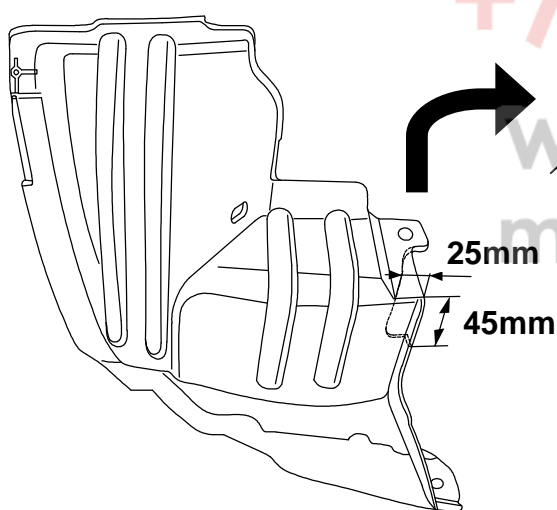

Fig. 3 Modification of mud guard.



PPUH AUTO-HAK S.J.

Produkcja Zaczepów Kulowych
Henryk & Zbigniew Nejman
76-200 SŁUPSK ul. Słoneczna 16K
tel/fax (059) 8-414-414; 8-414-413
E-mail: office@autohak.com.pl
www.autohak.com.pl

Towing hitch (without electrical set)

Class: **A50-X** Cat. no. **Y35**

Designed for:
Manufacturer: **HONDA**
Model: **JAZZ**
Type: **5 doors**
produced since 10.2008

Technical data:

D-value: 6,1 kN
maximum trailer weight: **1000 kg**
maximum vertical cup mass: **95 kg**

Approval number according to Directive 94/20/EC: **e20*94/20*0851*00**

Foreword

This towing hitch is designed according to rules of safety traffic regulations. The towing hitch is a safety component and can be install only by qualified personnel. Any alteration or conversion of the towing hitch is prohibited and would lead to cancellation of design certification. Remove insulating compound and underseal from vehicle (if present) in the area of the matting surfaces of the towing hitch. The vehicle manufacturer's specifications regarding trailer mass and max. vertical cup mass are decisive for driving whereat values for the towing hitch cannot be exceeded.

D-value formula:

$$\frac{\text{Max trailer weight [kg]} \times \text{Max vehicle weight [kg]}}{\text{Max trailer weight [kg]} + \text{Max vehicle weight [kg]}} \times \frac{9,81}{1000} = D \text{ [kN]}$$

NOTE

After install the towing hitch you should get adequate note in registration book (at authorised service station). The car should be equipped with:

- Indicators
- Tow mirrors

After 1000km of exploitation check all bolts and nuts. The ball of towing hitch must be always kept clear and conserve with a grease.